



HarvSense

António Rosário, Guilherme Gameiro, Lourenço Reis, Manuel Clemente, Pedro António



I. Problem

- **Structural Health Monitoring (SHM)** is essential to ensure the safety and longevity of critical infrastructure, such as bridges, buildings, wind turbines, and pipelines.
- SHM sensors typically rely on batteries or cables.
- In remote locations, installation and maintenance become expensive and limits scalability.
- These structures generate continuous mechanical vibrations, which can be converted into electricity through energy harvesting to power sensors.

II. Beneficiaries



Asset owners and operators



Maintenance companies



Maintenance companies

III. Layout

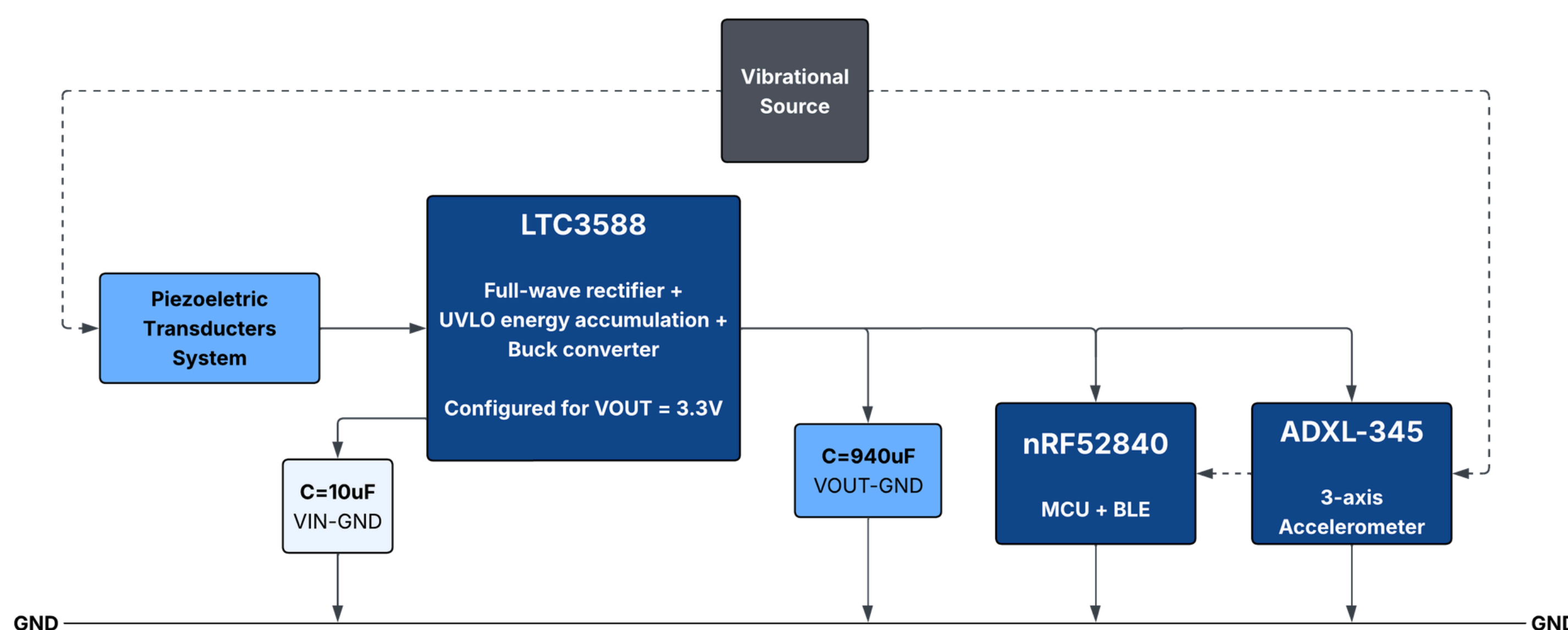

IV. What could the solution predict?

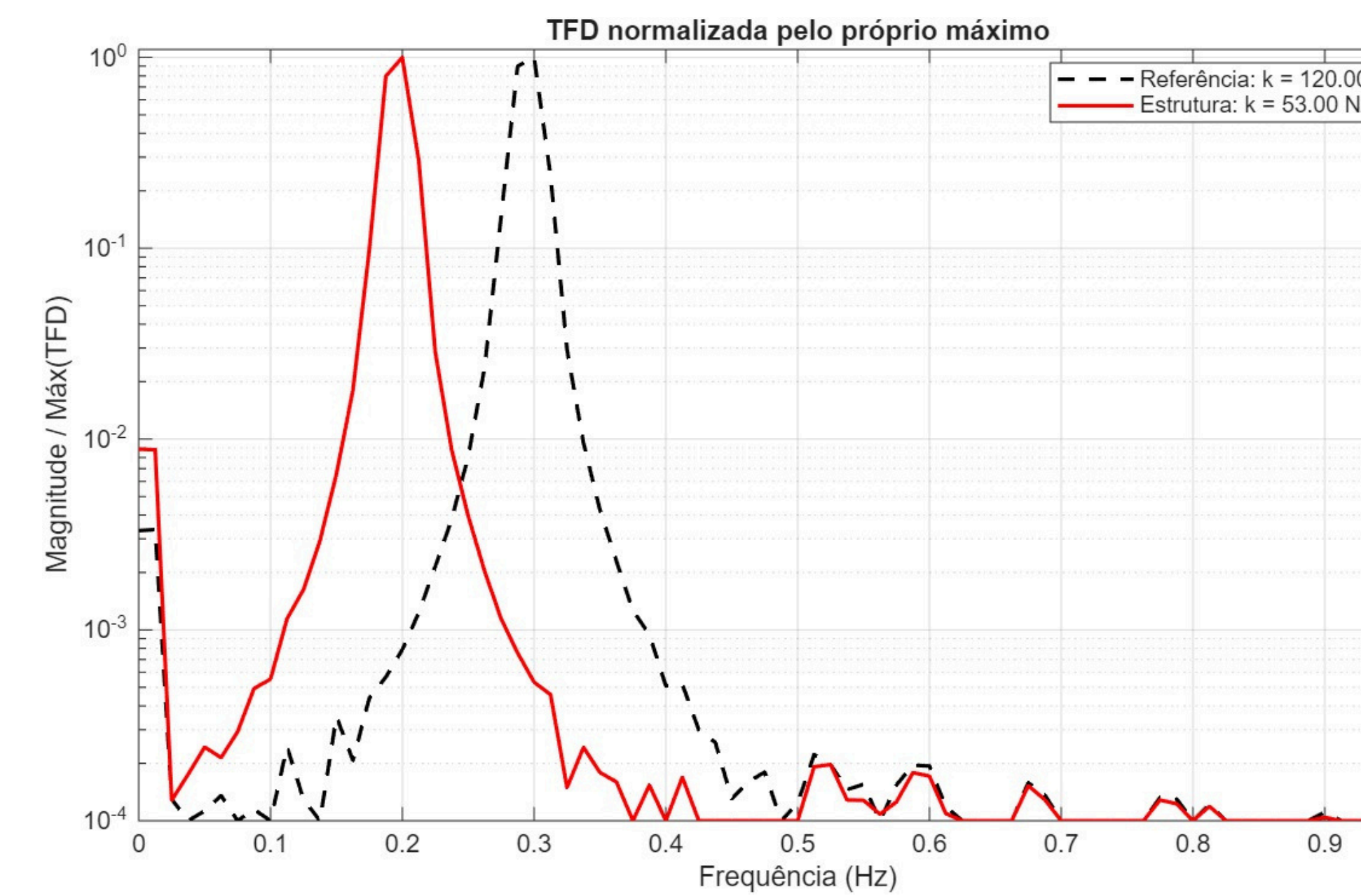

- Loss of **structural rigidity**, which decreases the structure's natural frequency. In the DFT, this effect is observed as the main peak shifting towards lower frequencies.
- Increase in **internal damping**, which causes the vibration to decay faster. In the DFT, the main peak has lower amplitude and may become more wider and flatter, reflecting greater energy dissipation.
- Appearance of **nonlinearities**, such as cracks. In the DFT, the main peak may shift towards higher frequencies, and secondary peaks or harmonics may appear, showing that the response is no longer purely linear.

V. Process

- **Piezo testing** → 4 piezoelectric transducers connected in series to increase the generated voltage.- -
- **LTC3588 validation** → Rectification and energy harvesting stage tested with the piezoelectric input.-
- **Voltage stabilization** → Capacitors tested to store energy and obtain a stable supply voltage.
- **ADXL345 testing** → Accelerometer validated for 3-axis vibration acquisition.
- **MCU + BLE integration** → XIAO nRF52840 processes vibration data and transmits it wirelessly.
- **Final prototype** → All modules integrated on a compact board for structural vibration monitoring.

VI. Results

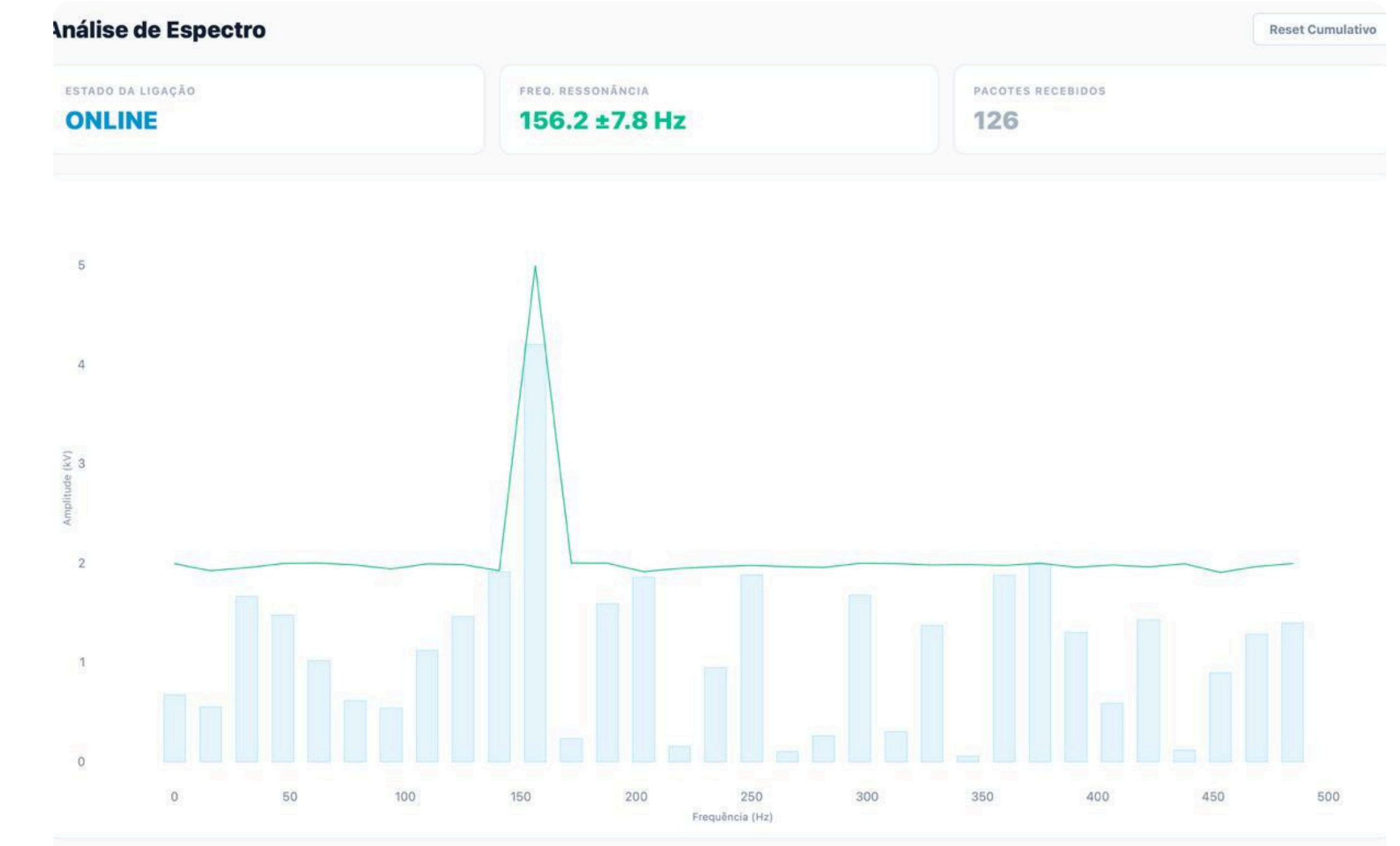

- **Main Achievement:** Compact prototype integrating energy harvesting, sensing and BLE communication; vibration data acquired using the ADXL345 accelerometer; FFT analysis successfully identified the dominant vibration frequency. The system demonstrates potential for battery-free structural vibration monitoring
- **Main limitation:** harvested energy is still limited for continuous BLE transmission.

