

 FLARE

Fire Localization and Aerial Research Ecosystem

 LEEC – PIC1



[FLARE site - link](#)

[FLARE video - link](#)

Our Team



**Augusto
Fragoso**

107122



**Guilherme
Andrade**

109618



**Margarida
Amaral**

109715



**Matilde
Nunes**

105834



**Pedro
Gouveia**

93154

Scientific Advisor: Prof. Ayman Radwan
Scientific Co-advisor: Mariana Santana

The Problem

Wildfires are detected too late

8 200 rural fires in
Portugal this year

269 000 hectares of
burned area

In remote areas monitoring is:

- limited,
- delayed,
- too expensive.

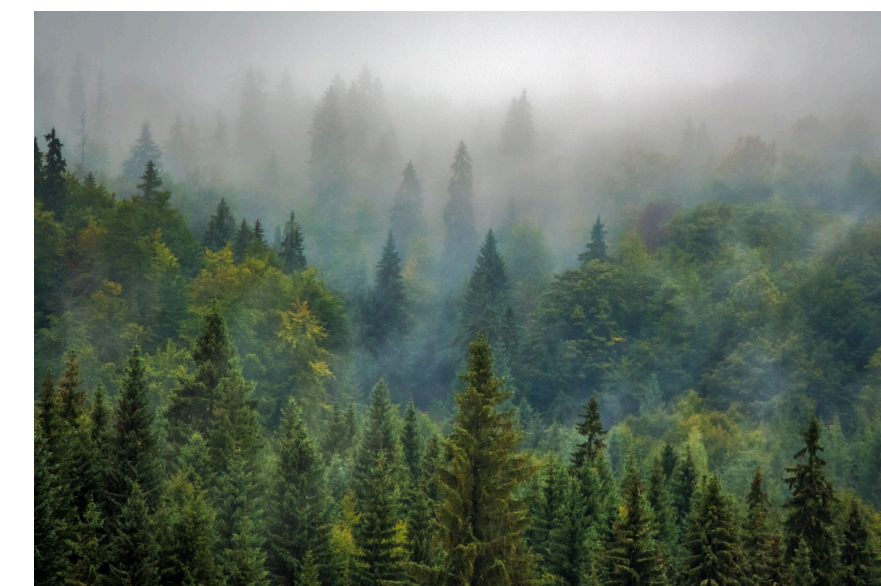
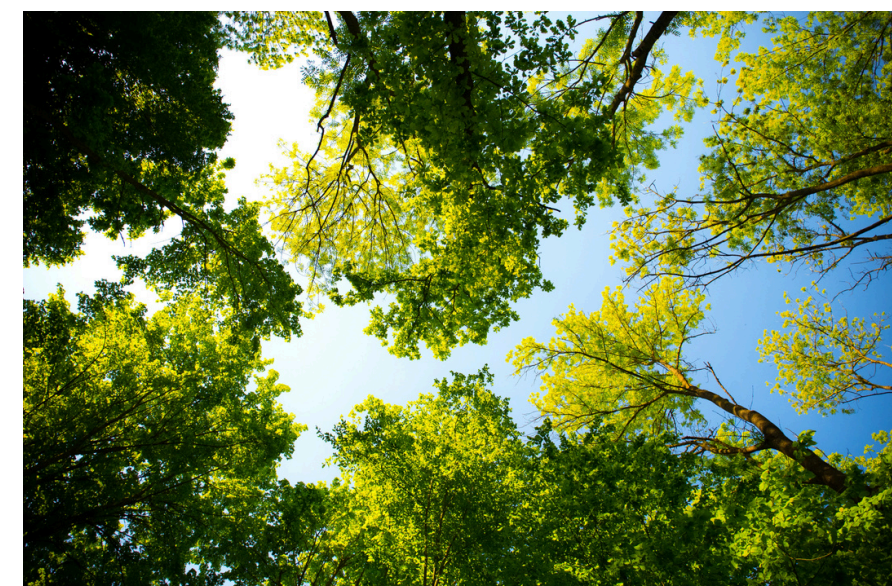

Proposed Solution



To address this problem we present the **FLARE** solution – an **ecosystem combining cheap stationary sensors with small drones** that can provide a more precise and quick response to wildfires.

This method allows for **maximum area coverage** with **minimal infrastructure needed**, as well as low energy consumption, ensuring affordability for mass deployment.

Solution Beneficiaries

The primary beneficiaries of the FLARE project include the fire departments and civil protection agencies, who directly benefit from receiving precise coordinates and real-time data, enabling faster and safer responses.

Additionally, local communities and property owners in high-risk areas benefit from early detection, which protects lives, homes, and agricultural assets.

Finally, reduced operational costs in firefighting and damage mitigation present a great advantage to municipalities and the government, while the local environment and biodiversity are preserved.



Firefighters



Local Communities



Competitors and Previous Work

Currently, wildfire detection in Portugal is addressed by several existing systems:

- Wildfire.pt – satellite-based fire detection and monitoring platform.
- CICLOPE (INOV) – remote monitoring towers with optical and thermal cameras.
- Projeto SenForFire – wireless ground sensor networks for early fire detection.
- Leitek Innovative Solutions – drone-based and optical wildfire detection systems.

These solutions typically rely on a single detection modality.

While effective within their scope, isolated approaches may suffer from limitations such as **delayed detection** (satellites), **false alarms** (ground sensors), **high infrastructure costs** (monitoring towers), or **operational inefficiency and expense** (continuous drone deployment).

What Makes Us Different

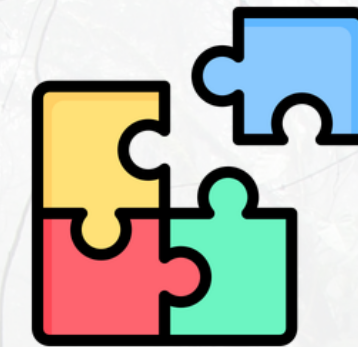

Smarter monitoring:
Lower Cost,
Higher Reliability in remote areas.

- Uses existing sensor + drone tech (no reinvention)
- Low-power communication (LoRaWAN + LTE)
- Event-triggered drone deployment
- Scalable via existing infrastructure

Market Validation

Questionnaires were made to potential users with the focus:

What information is needed during a wildfire event

The key data requirements were

Real-time location (with an accuracy threshold of 100 m) + **visual data**

Existing **technology acceptance**: Drone-based monitoring is already used.

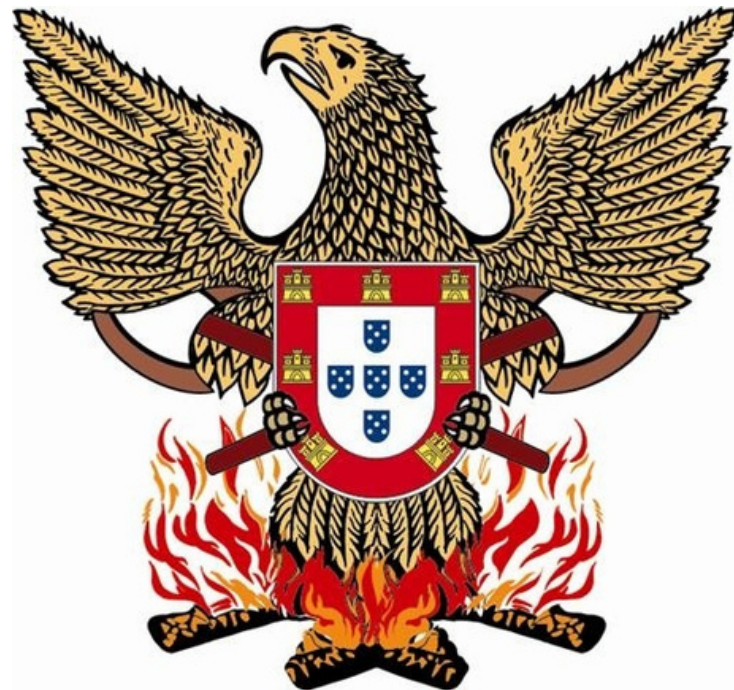

Lisboa
Coimbra



Coimbra

Technological Solution

The FLARE solution implements a hybrid ecosystem combining a ground-based **Wireless Sensor Network (WSN)** with autonomous UAV drones.

- Low-cost temperature, smoke, and CO sensors are strategically distributed across the area to continuously monitor environmental conditions.
- When an anomaly is detected, the sensors automatically transmit status data and coordinates via LoRaWAN.
- The processing unit receives the alert and triggers drone deployment.
- The drone is sent to the detected location for visual verification.

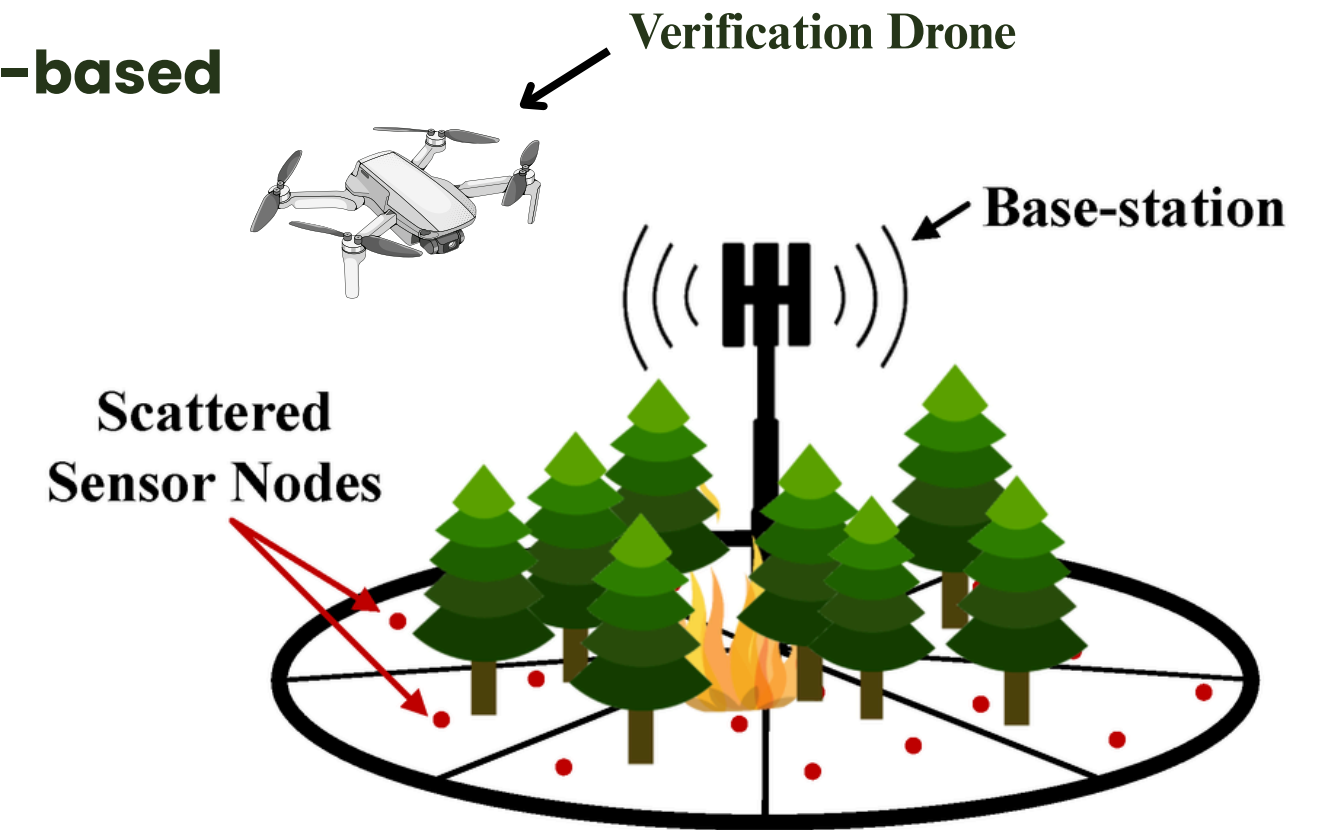
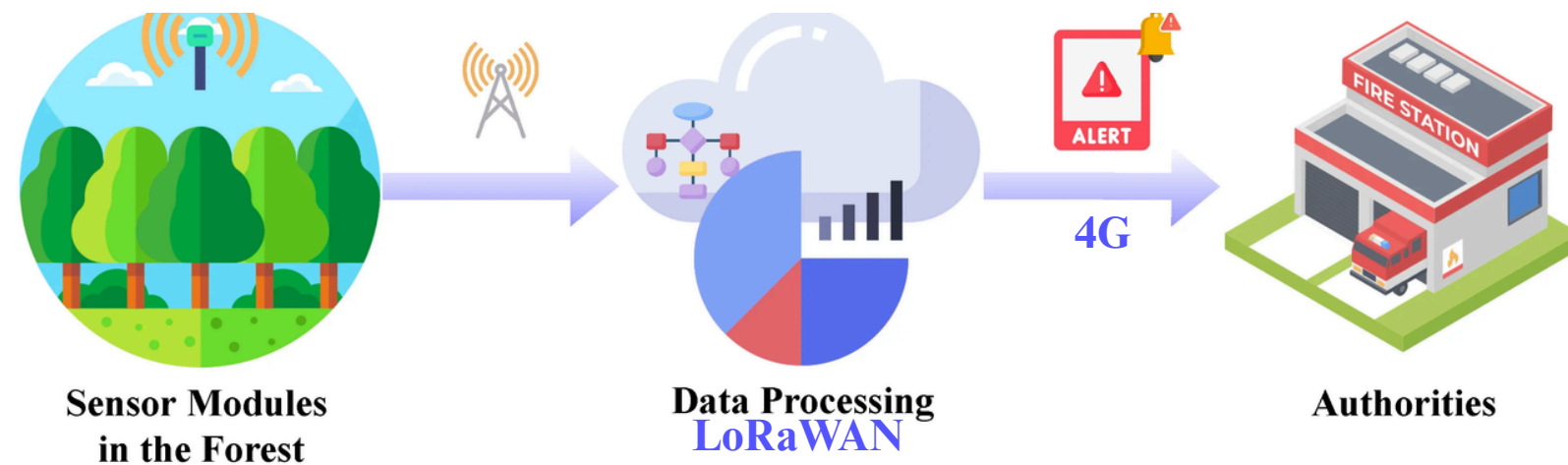

- The drone captures images, which are analyzed by the processing unit using computer vision.
- These images, combined with any other relevant information, are sent via 4G to the nearest fire department.

Our Solution

- LoRa connection
- 4G connection
- Internet connection

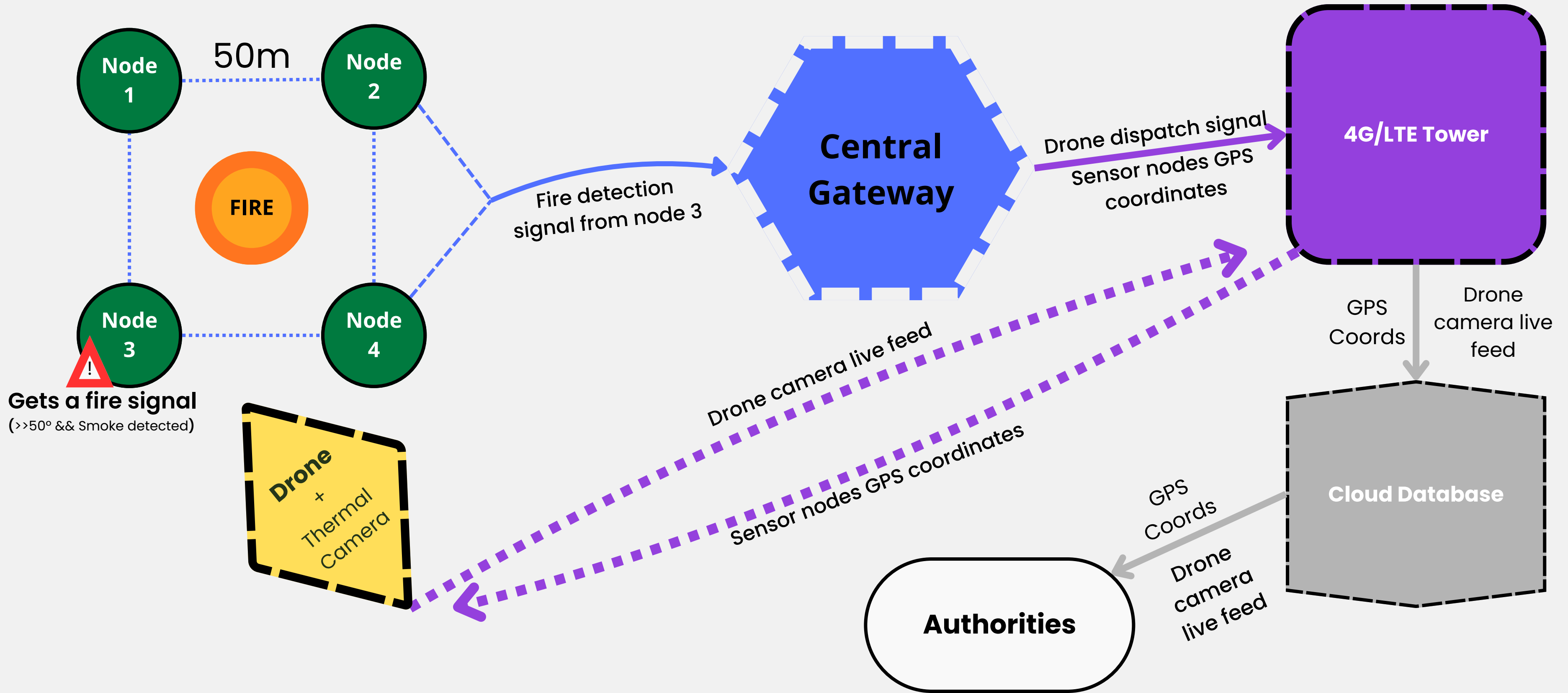

Forest environment with very little infrastructure

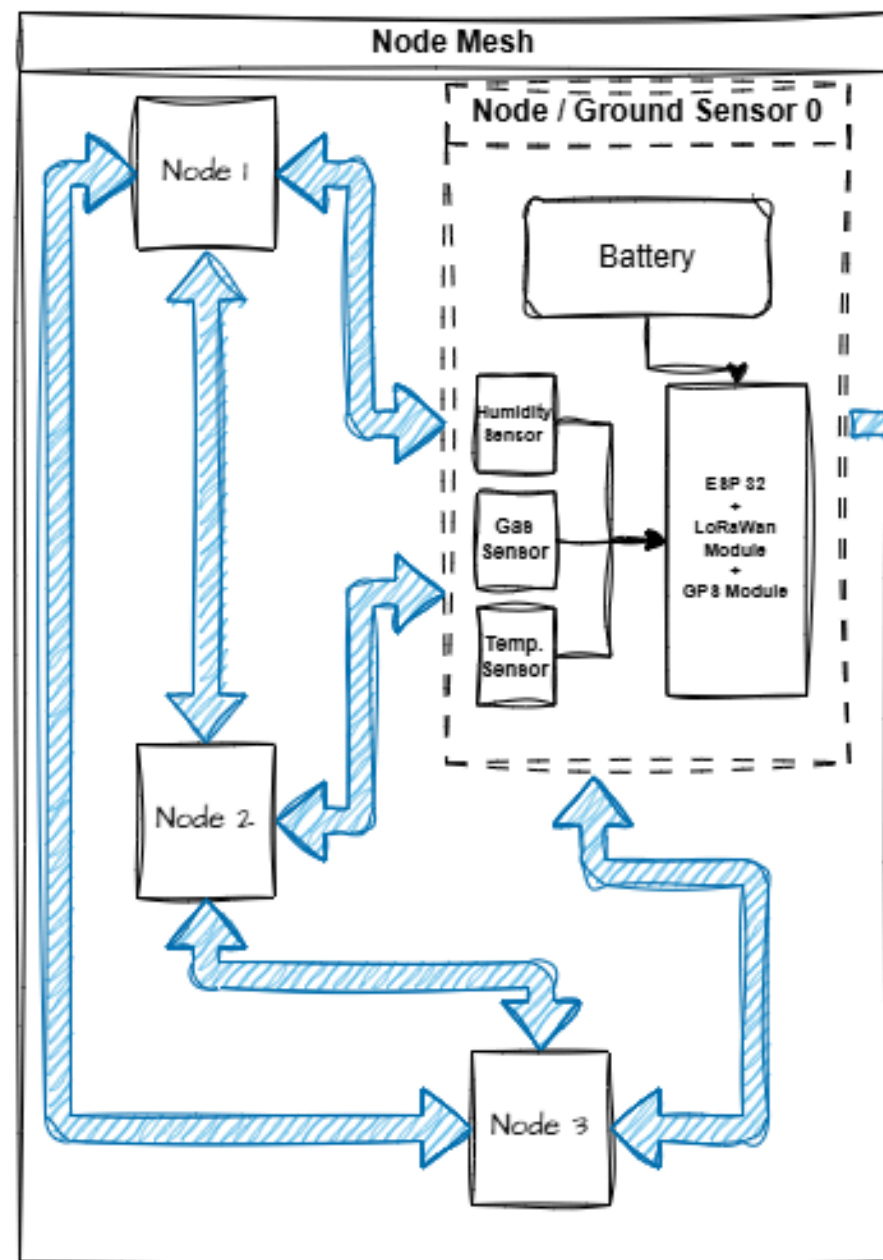

- Internet Connection
- 4G Connections
- LoRa Connections
- Electrical Cable / Soldered

Fire detector Sensor
GPS Coords
FIRE = True

Central LoRa Gateway

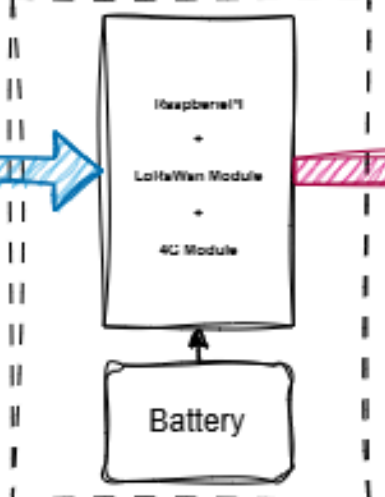

Fire detector Sensor
GPS Coords
FIRE = True



Some communication infrastructure present

General Architecture



Fire detector Sensor
GPS Coords



Fire detector Sensor
GPS Coords

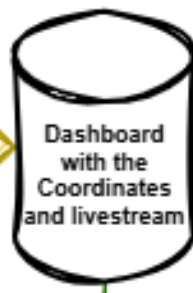
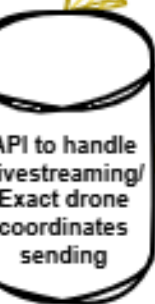

Internet/ API environment

Exact Coordinates and Livestream

Firefighters and other authorities

Ideal Hardware

- **Thermal (IR), gas, temperature, and humidity sensors:** Responsible for the initial detection of potential fire outbreaks. These sensors are distributed across the terrain and constitute the first layer of the system.
- **LoRaWAN communication:** Each sensor node is equipped with LoRa communication capability, enabling the efficient transmission of data (GPS coordinates and environmental measurements) to the gateway with low energy consumption. Ideally the LoRa network would be formed mesh-tastic, since it would enable LoRa-hopping through **LoRaWAN** protocols, thus the nodes would be able to communicate with each other, at the cost of more battery consumption.
- **GPS module:** Enables autonomous navigation to the alert coordinates and implements geofencing logic (50 m radius), determining the transition between operating modes (idle/active).

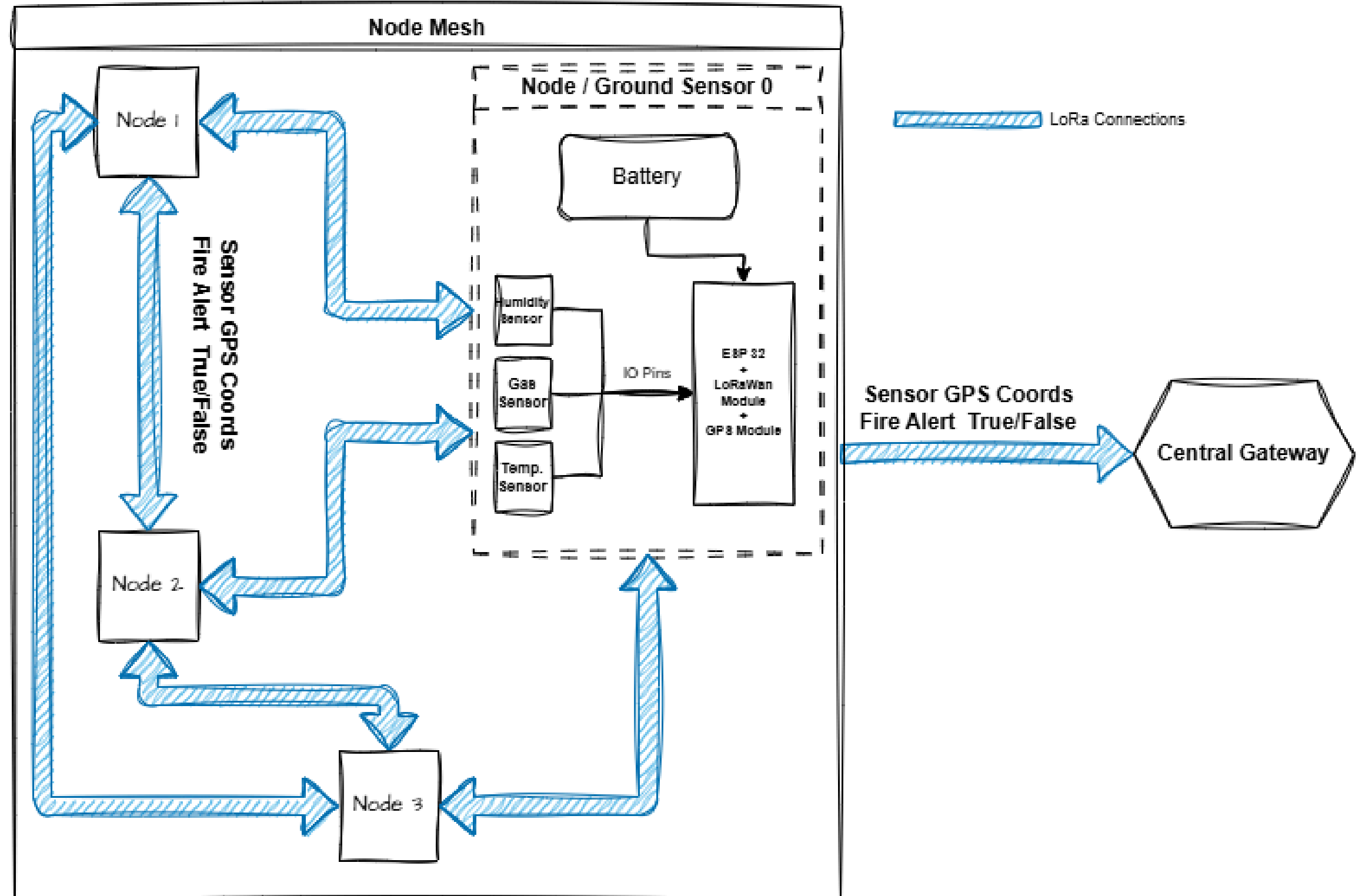

Ideal Hardware

Ideally to pair with the meshtastic nodes, we would need to develop a gateway compatible with them, to do that we would use:

- **Raspberry Pi 4 with LoRa HAT and 4G HAT:** Acts as a bridge between the sensor network and the cloud. It receives data from the sensors via LoRaWAN and retransmits it through a 4G connection to the cloud infrastructure.
- **MCU (Microcontroller):** Handles system state management (idle vs active), basic flight control, and coordination of onboard modules.
- **Edge computing:** Runs computer vision algorithms (Leitek), enabling validation of incoming data and reducing false positives.

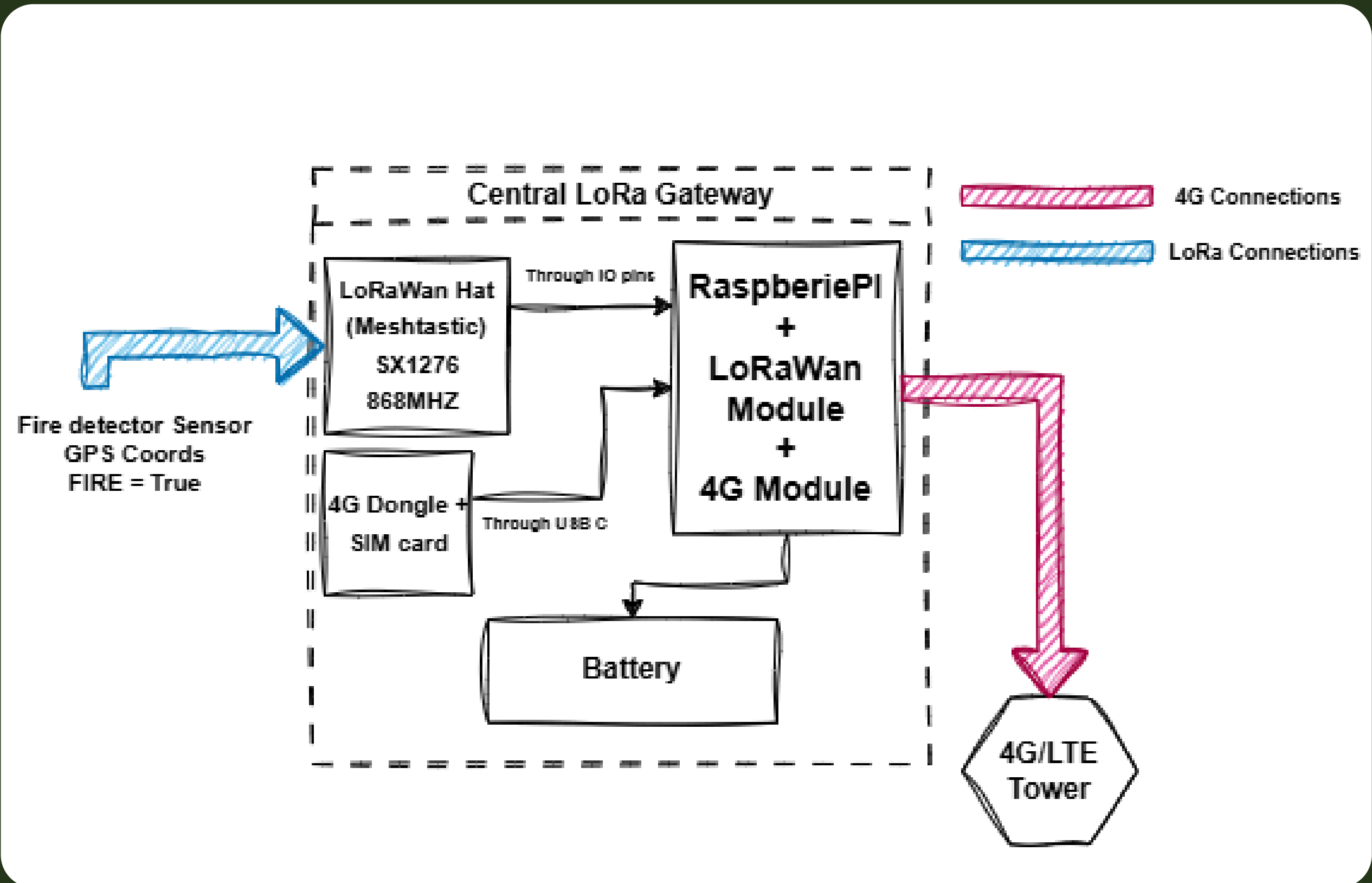

Software

- **Cloud platform and APIs:** Responsible for receiving, storing, and distributing data from the sensors. The central API manages alert events, GPS coordinates, and communication with the remaining system modules.
- **Drone mission management:** After detecting a potential fire, the system can automatically (or with manual confirmation) trigger the drone, sending the alert's GPS coordinates for autonomous navigation to the location.
- **Data processing:** Incoming data (sensor readings and video) is analyzed using computer vision algorithms and AI models.
- **Monitoring dashboard:** Visual interface for users.

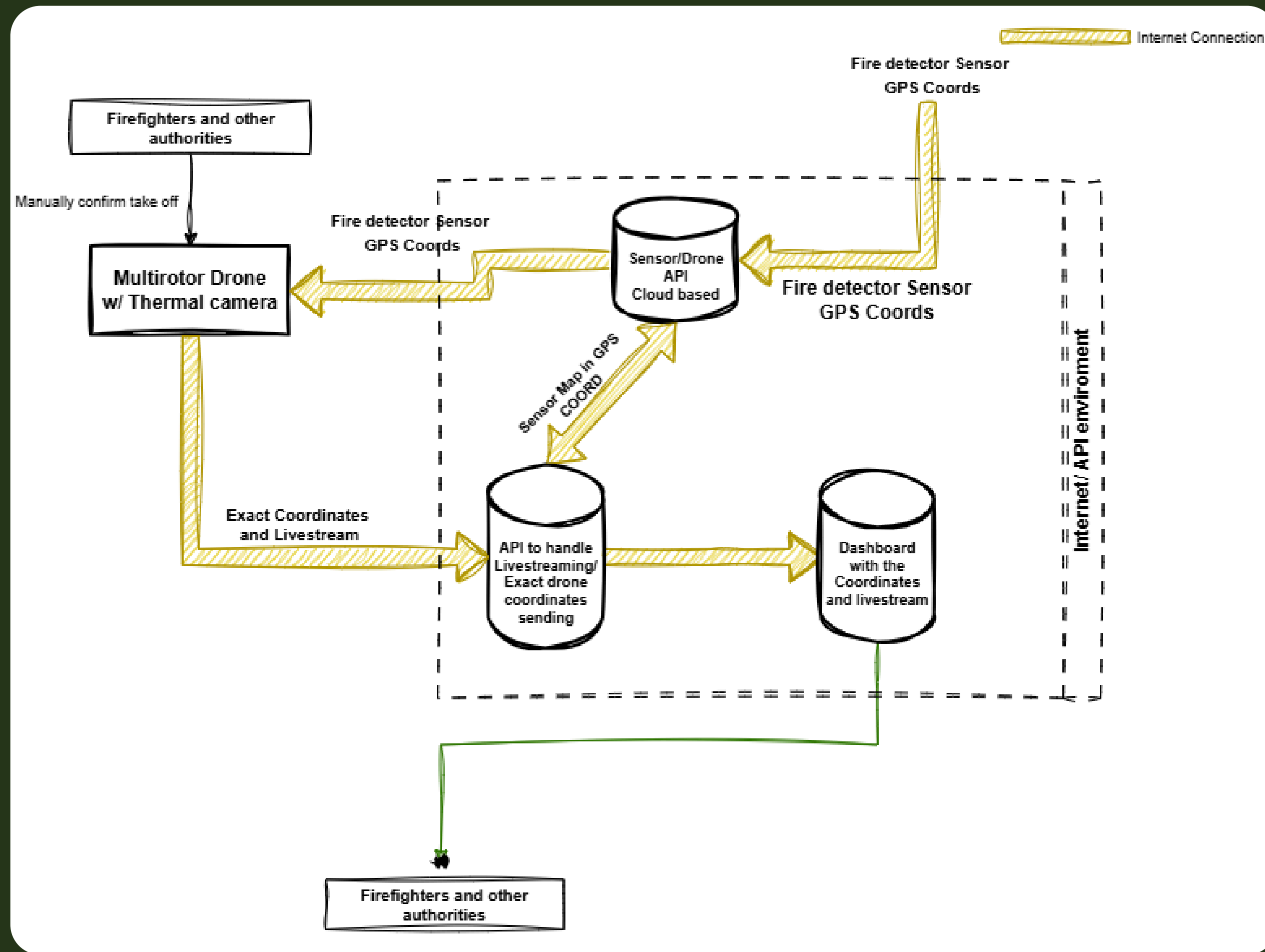

Prototype Results

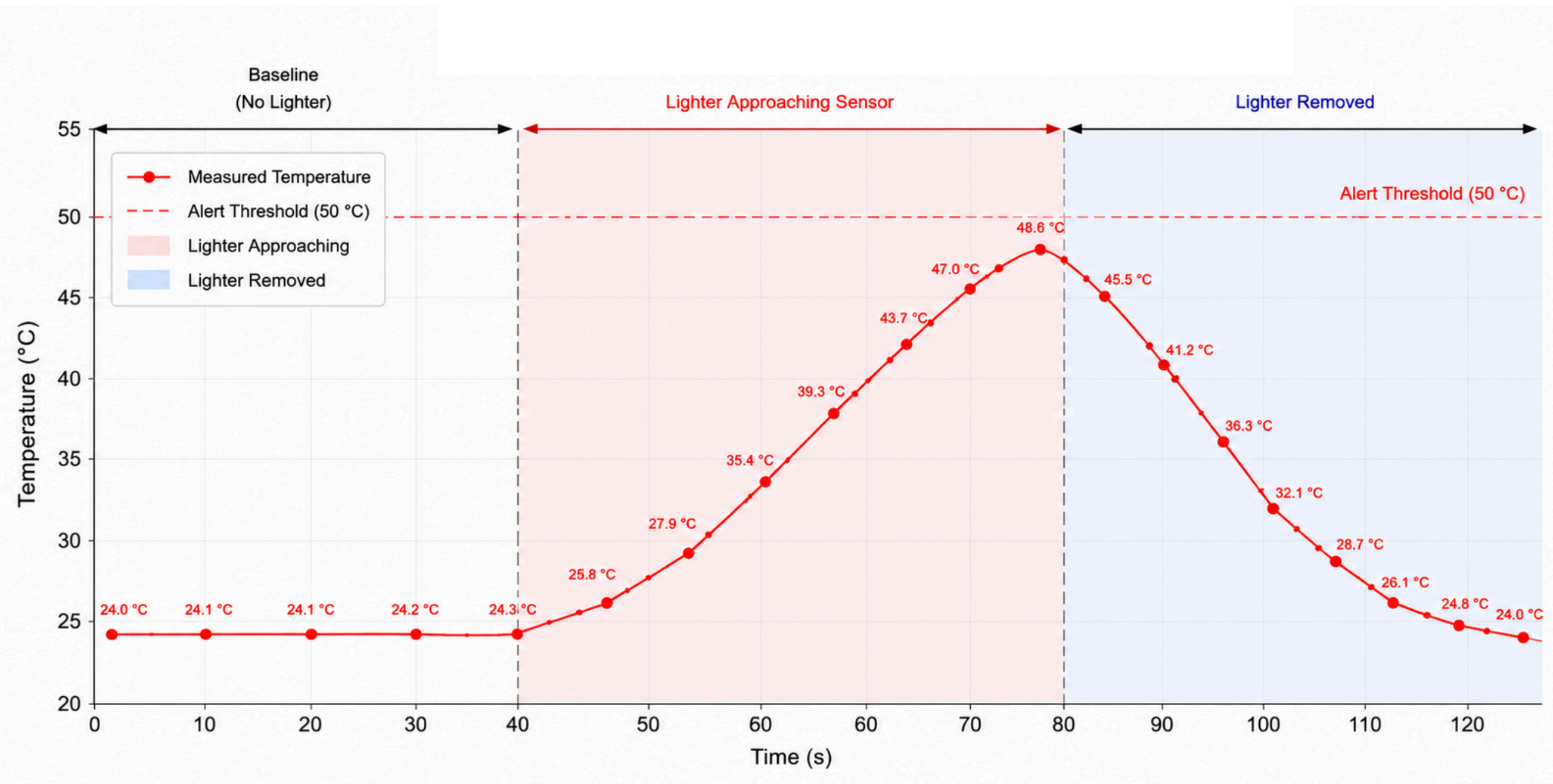

Setup

- 2 sensor nodes developed
- ESP32 + DHT11 + LoRa module
- Local environment testing

End-to-End Simulation Results

Environment

- Area: 500 m²
- Terrain: Rural / forest area model
- Sensor deployment: Grid distribution

Sensor Network

- Number of sensor nodes: 5 nodes
- Node sensing radius: ~50 m
- Communication protocol: LoRa
- Frequency: 868 MHz
- Gateway position: Central location

Fire Event Simulation

- Ignition point: Random position inside monitored area
- Detection method: Threshold-based
- Temperature threshold: 50 °C
- Gas threshold: 800 A.U.

Pipeline Summary — Node -> LoRa -> TTN -> Drone

Fire starts	t = 129s (random)
Weibull shape c	2.17 (fire growth profile)
Node 2 detects (DHT22+MQ2)	+61s after start
LoRa TX (RFM95 868MHz)	Air time: 51.5 ms
TTN Gateway -> 4G/LTE	Latency: ~2s
Drone dispatched	Total: 64.1s

Costs

- **Hardware**
 - Low-cost temperature/smoke sensors
 - LoRa communication nodes
 - Drone + camera system
- **Infrastructure**
 - Cloud platform
 - Data processing
 - Maintenance
- **Operation**
 - Installation
 - Monitoring
 - Periodic replacement

Benefits

- **Lower monitoring costs**
 - Reduces the need for constant human surveillance
 - Less reliance on continuous drone flights
- **Optimized drone operation**
 - Drone is deployed only after sensor detection
- **Reduced firefighting costs**
 - Earlier detection → smaller fires
 - Less resources needed for suppression
- **Reduced damage costs**
 - Protects forests, agriculture and infrastructure

Work Division

Augusto	Guilherme	Margarida	Matilde	Pedro
<p>Backend + Dashboard Implement a backend service to receive data from firebase, process alert conditions, and store sensor data. Develop a simple dashboard to display sensor readings and alert locations in real time.</p>	<p>Partners Contact + Sensor Nodes Build ESP32-based nodes by integrating DHT11 and MQ-2 sensors, and program data acquisition. + Power System Assemble the power circuit by integrating Li-Ion batteries, a charging module, and voltage regulators, while connecting the solar panel as the energy source.</p>	<p>Pitch Decks + Video + Simulator Simulate wildfire scenarios to evaluate sensor mesh and coverage, alert detection time, communication performance, and drone deployment response.</p>	<p>Poster + Site + Lora + Esp32 Configure the communication system by integrating ESP32 nodes with LoRa modules. Implement sensor data transmission, define the communication protocol.</p>	<p>3D Modeling Design and develop the 3D enclosure for the sensor nodes. Optimize the for sensor exposure, battery integration, and easy maintenance.</p>

Timeline

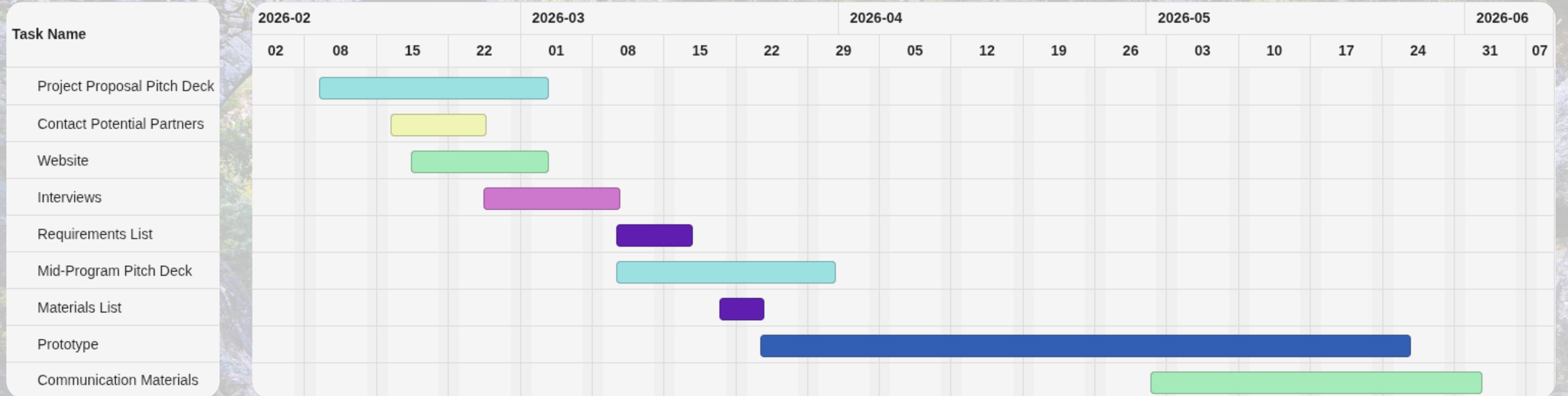



Thank You!



DEEC
DEPARTAMENTO DE ENGENHARIA
ELETROTÉCNICA E DE COMPUTADORES
TÉCNICO UNIVERSIDADE DE LISBOA

