

ElectroCap Pitch Deck (Automated Alarm System)

Monitoring Smart Home Security (Team 12)

Francisco Carmo ist1103618

Francisco Henriques ist103714

Gonçalo Amaral ist1102608

João Saraiva ist1102631

Miguel Neves ist1103462

Pedro Paiva ist196900



TÉCNICO LISBOA

Problem

Nowadays most alarm systems implemented in people's homes aren't totally automated, needing someone to manually enable or disable them. Our focus is to implement an alarm system whose purpose is to control the access to the apartment while making it as automatic, robust and reliable as possible.

A restriction/disadvantage of an automated alarm system might be the cost of its components.



Solution/Product (I)

The technical solution for the given problem is the development of an automated alarm system through a central computation unit that supports incoming sensory inputs from a myriad of sensor types, such as cameras and motion sensors. As such, the only fully-mandatory requirement in terms of hardware would be a central computer. Said central computer would run software that implements a solution incorporating input from several types of sensors, accounting for implementations where there are more/less sensors installed, and correspondingly adapting said solution. The amount and type of sensors implemented in each scenario can therefore be variable.



Solution/Product (II)

Our solution involves installing a door camera to capture video when a motion sensor detects movement, which will undergo facial recognition algorithms. Additionally, an overhead door camera will monitor movement in the area to track individuals entering or exiting the apartment.

The system will also use an app that provides an easy way for users to manage their alarm system, providing information about suspicious activities as well as giving the user control over the system functionalities, such as disabling the alarm after they have been made aware of the possible threat at hand.



Solution/Product (III)

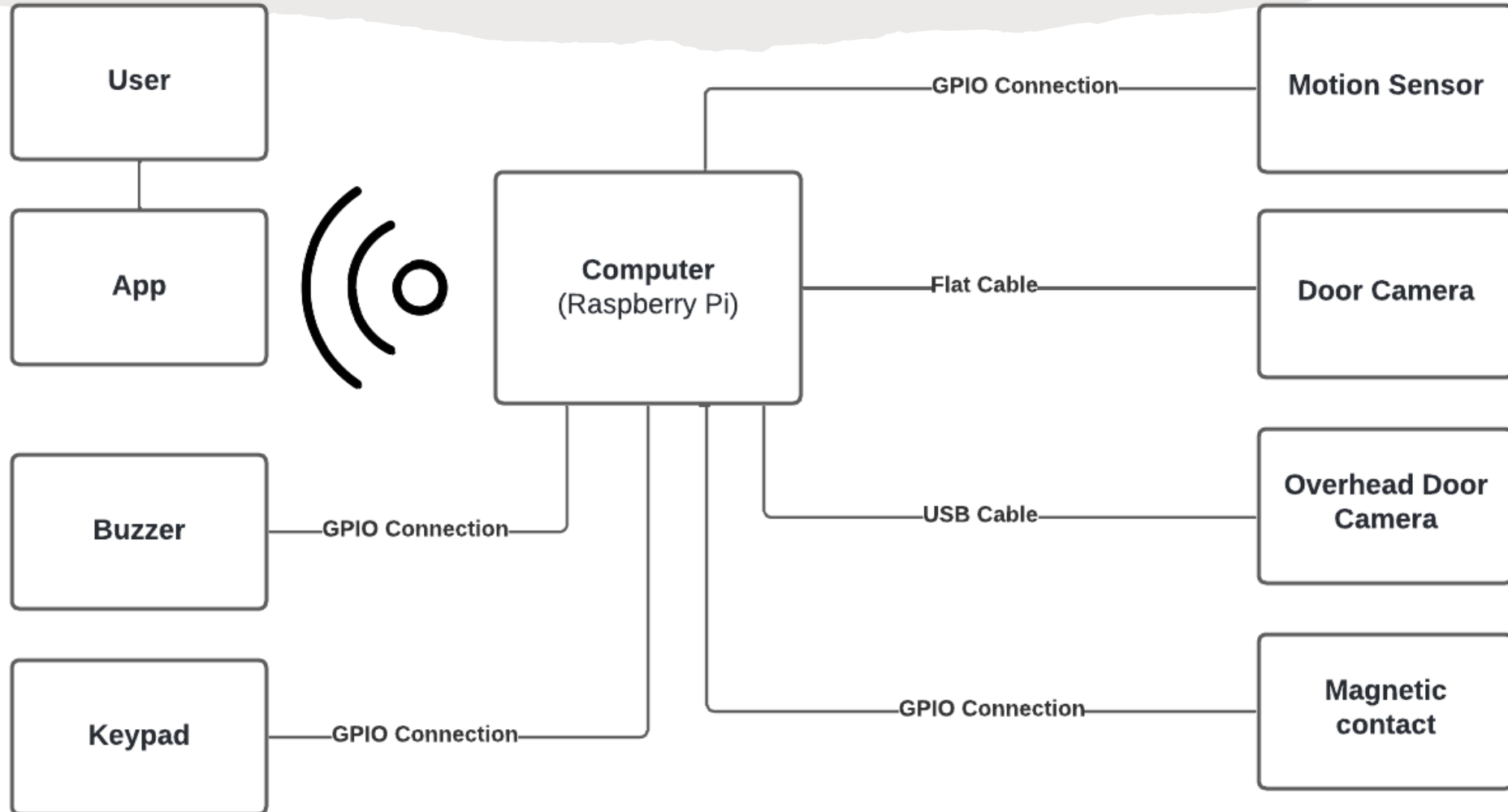



**Solution/Product
(Logical Sequence)**

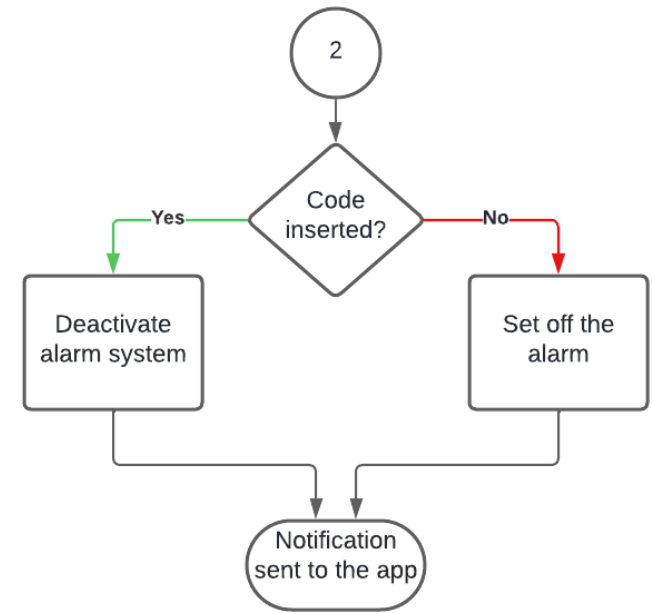
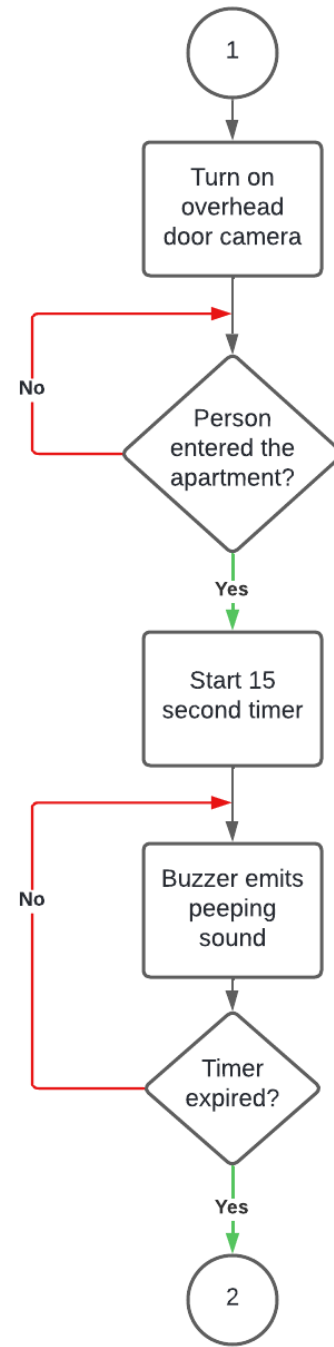
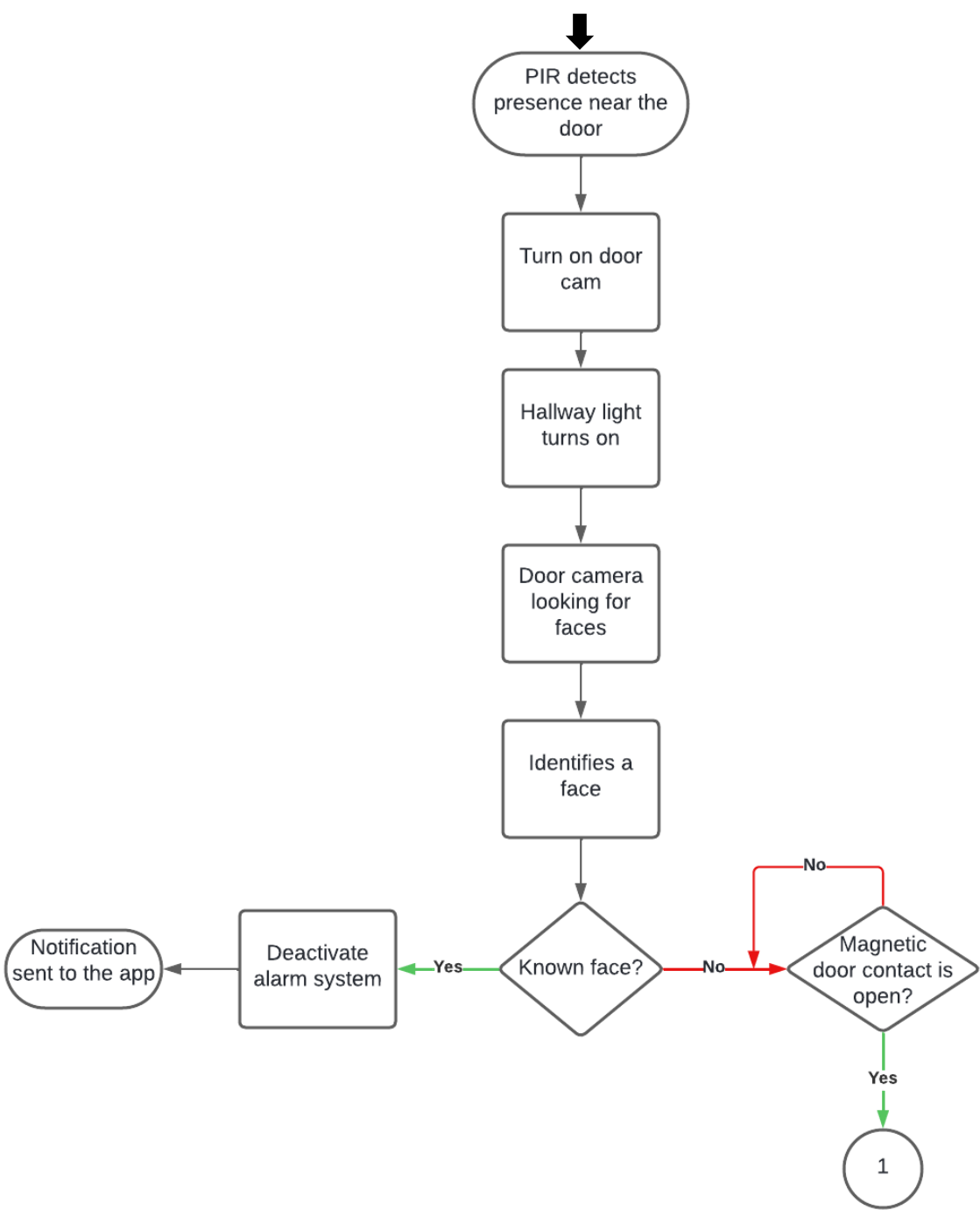

Target Audience

The segment of society that benefits from the alarm includes the owners of the apartments where it is installed, as well as their neighbors.

Anyone who owns an apartment and is concerned about its safety can benefit from this solution, as it increases the reliability of its security. Neighbors of homes with this solution implemented can also benefit, since better security in one home allows better alerts to be given to neighboring homes.



Competitors

Existing alarms end up not being completely automated resulting in the need to manually operate them. Some companies that sell these products are Securitas, Ring, Prosegur, etc.

Site Securitas : <https://www.securitasdirect.pt>

Site Prosegur : <https://alarmes.prosegur.pt>

Site Ring : <https://eu.ring.com/>



Team

- **Scientific Advisor:** Prof. Luís M. Correia
- **Coordinator:** Prof. Luís M. Correia
- **Mentor:** Prof. João Felício



Gonçalo Amaral



Francisco Henriques



Pedro Paiva



Francisco Carmo



Miguel Neves

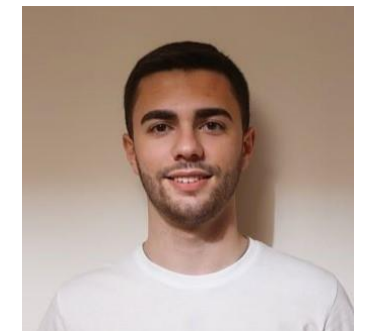

João Saraiva



Results

After conducting tests at the hardware level, we confirmed that the minimum distance between the user and the camera for facial recognition is 80 centimeters. Our solution is highly scalable as it:

- Can integrate more sensors - not all Raspberry pins are utilized;
- Is compatible in homes with varying dimensions.

Despite the obstacles encountered, we were able to develop a solution for the proposed challenge similar to the initially presented proposal. Some technologies, such as RFID tags, had to be discarded due to technical and implementation problems. In the end, we managed to develop a fully automatic alarm system that controls access to apartments, notifying the owners through our app and providing a picture from the door camera.

Team Members Contributions (I)

Miguel Neves	João Saraiva	Gonçalo Amaral
Team Communication	Motion Detection Software	Motion Detection Software
Hardware Research	Hardware Research	System Tests
Mid-Program Pitch Deck	System Architecture	Hardware Research
Reunion Planner	Testing and Validation Metrics (facial recognition)	Logical Sequence
System Code	System Code	App - Mockup
Poster	Prototype Construction	App - Notifications and Authentication
Video Recording	Video Recording	Video Recording
Raspberry Setup(Hardware Issues and libraries installation)	Raspberry Setup(Hardware Issues and libraries installation)	Video Editing
Pitch Deck	Pitch Deck	Pitch Deck

Team Members Contributions (II)

Pedro Paiva	Francisco Carmo	Francisco Henriques
Webpage Creation	Facial Recognition Software	Facial Recognition Software
Webpage Management & Blog	System Tests	System Tests
System Tests	Hardware Research	Camera Research
Hardware Research	App – Communication with Raspberry PI	App – Structure
Poster	Prototype Construction	Prototype Construction
Video Recording	Video Recording	Video Recording
Prototype Construction	Camera Research	App – Communication with Raspberry PI
		Testing App - Android Device



Costs and Benefits

The cost of the components that make up our alarm system sums up to around 130 euros, which is substantially cheaper than many alternatives offered by our competitors. Therefore, it can be inferred that our product benefits from being relatively affordable.

Our solution is also versatile, as it can be implemented with more sensors than those presented that serve different purposes.

Webpage

[Landing Page](#)

[Blog](#)

[Demo Video](#)

